

# ECOVOLVE ED800 ELECTRIC DUMPER

## TECHNICAL DATA



### CAPACITY:

Max safe load	1750 Lb
Unladen weight	2650 Lb
Skip -Leveled	12 Cubic feet
-Heaped	17 Cubic feet
-Water level	60 Gallons

### HYDRAULIC SYSTEM:

Gear Pump	
-Flow rate	1.45 Gallon / Min
-Oper. pressure	1900 PSI
Pump Motor	2.2 KW
Hydraulic tank capacity	0.74 Gallons

### DRIVE:

	One wheel drive
	One wheel steer
Speed	0-4 Mph
Steering angle	90°
Grade-ability	15°

### ELECTRIC SYSTEM:

Voltage	24V
Battery	400Ah
Integrated Charging	Input 100-240V AC
	Output 24V DC
Recharge	8Hrs

### TRANSMISSION:

Proportional	Drive
Steering	Electric
Tires	Super elastic
	2no. 27x8.5x15 front
	1no. 21x8x9 rear
Brakes	Dynamic electric brake
	Negative parking brake

### DRIVE MOTOR:

Type	Induction motor
Output	5 KW / 7Hp
Emission	Zero

### NOISE:

Driving	65Db
Buzzer	Adjustable 60-80Db

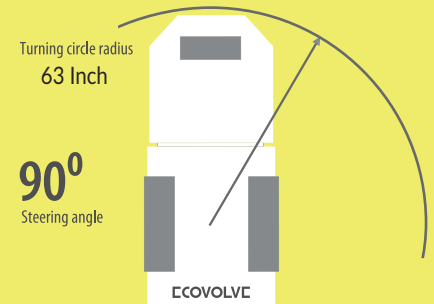
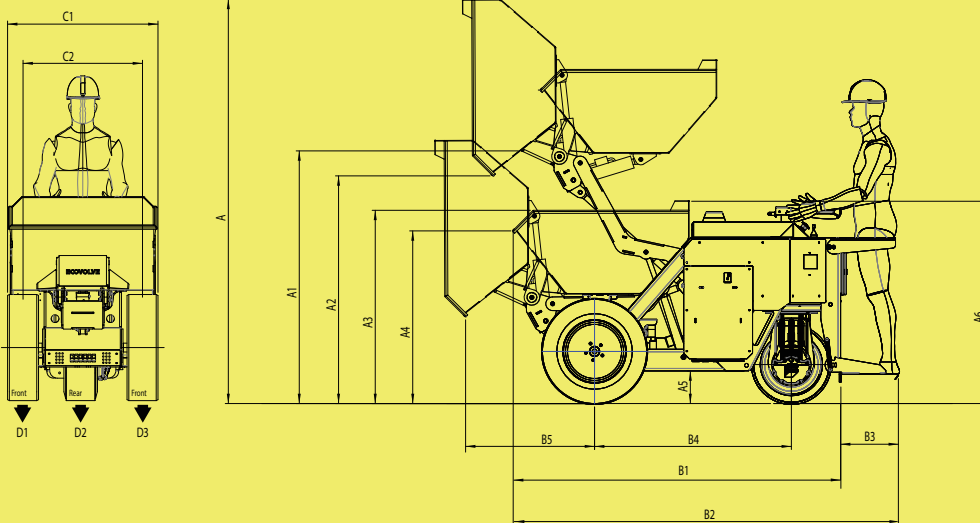

	A	A1	A2	A3	A4	A5	A6
in	103	64	58	50	44	8.3	51.5

	B1	B2	B3	B4	C1	C2
in	81.5	60	14.5	50	31	23

Ground Pressure (pounds)	D1 (Front)	D2 (Rear)	D3 (Front)
Unladen weight 2650 Lb	620	1400	620
Laden weight 4400 Lb	1430	1540	1430